



WATER & SOLAR COMPANY
WATER & ENERGY SYSTEMS

REVERSE OSMOSIS SYSTEM LPRO-B16-3000

Catalogue



LPRO-B16-3000

System Overview

- **Production: 0.5m³/hr (12m³/day)**
- **Membranes: 4040 x 2**
- **Feed TDS range: ≤ 2000ppm with standard membrane**
- **Typical salt rejection: 95 - 99%**
- **Power supply: 220V 50Hz Single phase**

Material Of Construction

- **Frame Work: SS304**
- **Low pressure piping: UPVC Class 16**
- **High pressure piping: UPVC Class 16**
- **Pressure vessels: FRP 300psi Pumps SS304**
- **Control Box: Mild steel epoxy coated**
- **Pre-filter housings: Big Blue 20"**

Instrumentation

- **Conductivity: Permeate**
- **Flow meters: Permeate, brine, brine recycle**
- **Pressure gauges: Pre & Post filter, Pre & Post membranes**
- **Pressure switches: Low pressure & high pressure**

Feed Water Conditions

- **Temperature 5 - 35 ° C**
- **TDS: ≤ 2000ppm with standard membrane**
- **SDI: < 5**
- **pH: 4 - 9**
- **Free Chlorine: Undetectable**
- **Iron: < 0.1ppm**
- **Manganese: < 0.05 ppm**

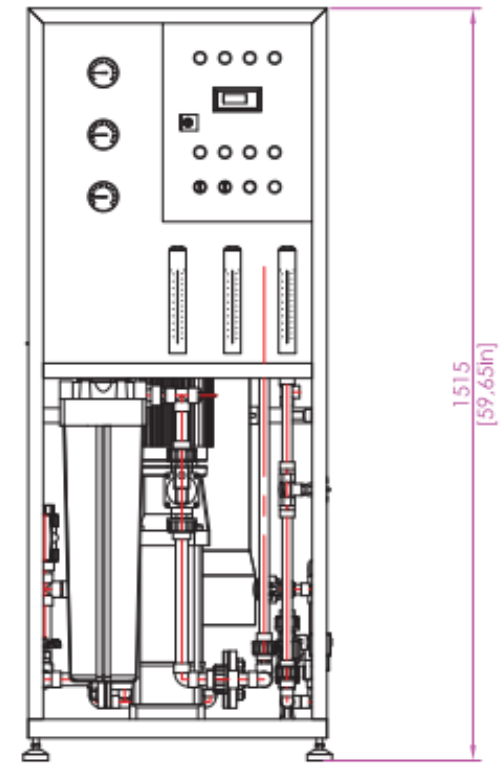
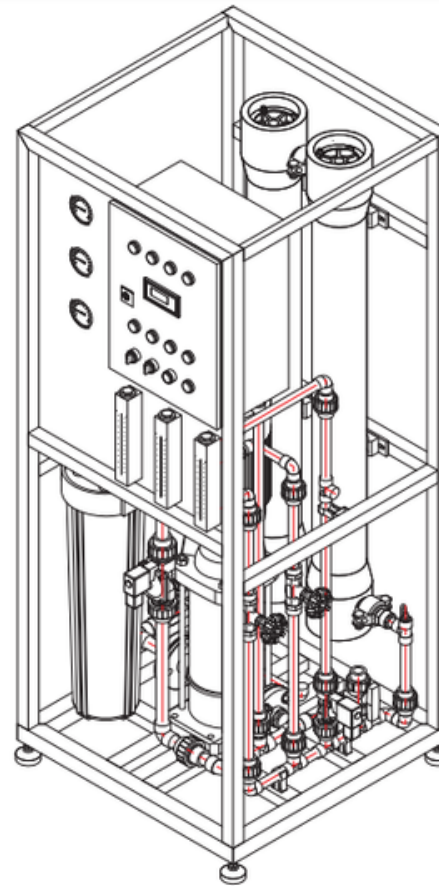
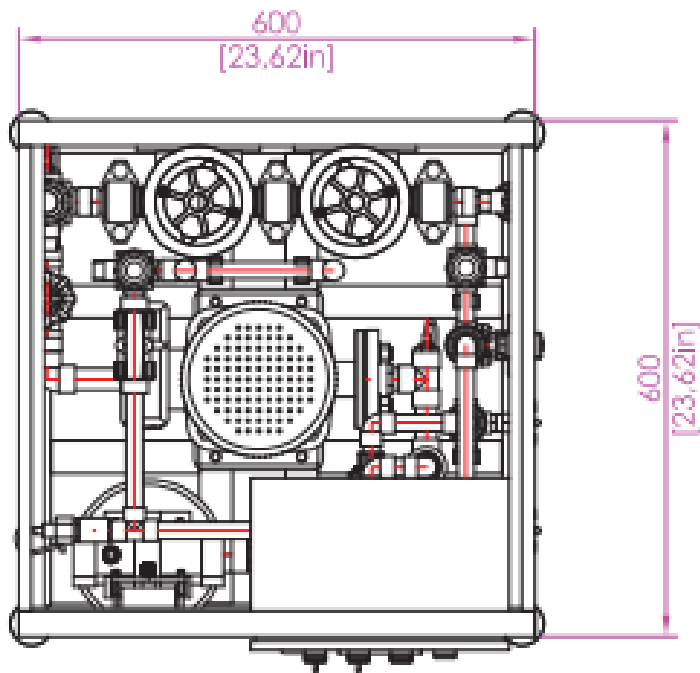

CRATED DIMENSION L (MM) * W (MM) * H (MM)	CRATED VOLUME (CUBIC METER)	GROSS WEIGHT (KG)	SYSTEM DIMENSION L (MM) * W (MM) * H (MM)	NET WEIGHT (KG)
690*730*1660	0.84	135	600*600*1515	102

***Specifications and dimensions subject to change**

***Permeate flows are maximums and may vary depending on feed water conditions**



+27 62 375 5088



+27 65 321 5803



<https://www.thewatersolarcompany.co.za/>



<https://maps.app.goo.gl/MBR2LMW3T6f9TtHV9>



<https://www.facebook.com/watersolarcompany>



<https://www.youtube.com/@TheWaterSolarCompany/>



<https://www.instagram.com/watersolarcompany2023/>