

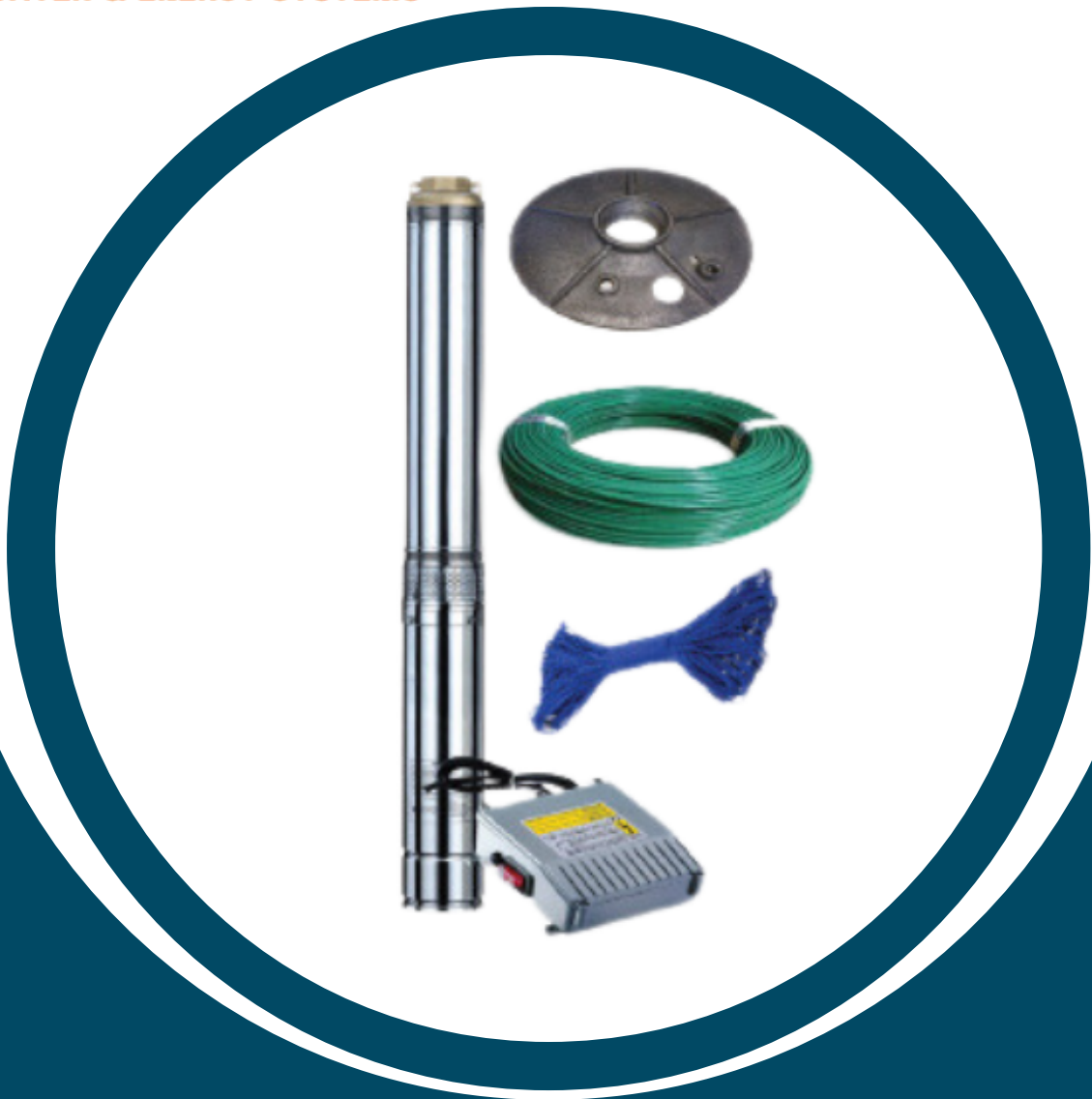

Product Catalogue



3SDM Borehole Pump Kit Version 2

3 SDM BOREHOLE RANGE

The 3 inch Borehole range consists of nine models from a 0.18kW – 1.5kW Single phase 220V, 50Hz.

The range is available in two versions.

Version 2 consists of a pump, motor, control box, baseplate, pre-joined cable and ski rope and is available in 0.18kW – 0.75kW.

The cable length ranges from 30m – 100m dependant on the pump model.

Applications

For water supply from boreholes, wells or reservoirs Continuous duty rated products for use in domestic, farming and irrigation applications.

Operating Conditions

Maximum fluid temperature up to: +35°C

Maximum sand content: 0.25%

Minimum well diameter: 4"

Materials of Construction

Components	Material
Wet End	
Pump external casing	AISI 304 SS
Delivery casing	Cast-Cu ASTM C85500
Suction lantern	Cast-Cu ASTM C85500
Diffuser	Plastic.PC
Impeller	Plastic.POM
Shaft	AISI 304 SS
Shaft coupling	AISI 304 SS
Wear ring	AISI 304 SS
Motor	
Motor external casing	AISI 304 SS
Top chock	Cast-Cu ASTM C85500
	Cast-Iron ASTM No.30
Bottom support	AISI 304 SS
Mechanical seal	Graphite - Ceramic
Shaft	AISI 304 SS - ASTM 5140
Bearing	NSK
Seal lubricant oil	Food grade oil

Motor and Pump

Replaceable Pump and Motor.

Single-Phase:

220 - 240V/50Hz Equipped with start control box

Curve tolerance according to ISO 9906

Warranty

1 year

(according to our general sales conditions)

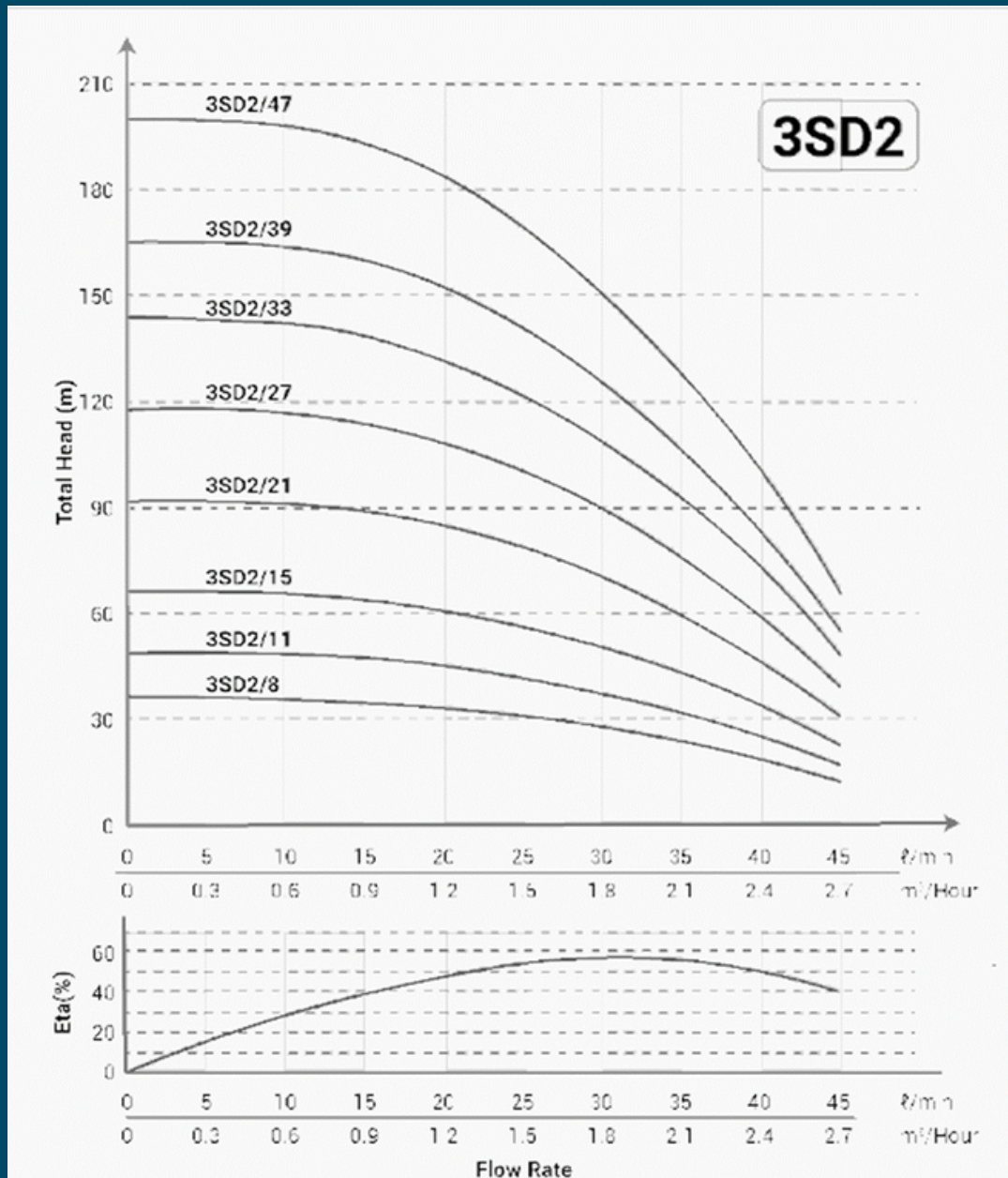

Performance Data 50 Hz

VERSION		MODEL	P2		CAP µf	DELIVERY										
1*	2**	220V ~ 1 Phase	kW	HP		m3/h	0	0.3	0.6	0.9	1.2	1.5	1.8	2.1	2.4	2.7
						l/min	0	5	10	15	20	25	30	35	40	45
v	v	3SDM2/8	0.18	0.25	16	Head (m)	35	34	34	33	32	29	26	22	17	11
v	v	3SDM2/11	0.25	0.39	16		48	47	47	46	44	40	36	30	24	15
v	v	3SDM2/15	0.37	0.5	20		65	64	64	63	60	55	49	41	33	21
v	v	3SDM2/21	0.55	0.75	25		91	90	90	88	84	77	68	58	46	29
v	v	3SDM2/27	0.75	1	35		117	116	115	113	107	99	88	75	59	38
v		3SDM2/33	1.1	1.5	45		143	142	141	138	131	121	107	91	72	46
v		3SDM2/39	1.1	1.5	45		168	167	166	163	155	143	127	108	85	55
v		3SDM2/47	1.5	2	55		203	202	201	196	187	172	153	130	102	66

* Version 1 Pump, Motor & Control Box

** Version 2 Pump, Motor, Control Box, Base plate, Cable (length - refer price list), Joint & Rope.

Note: Unit c/w maximum 1.5mm 4 core cable.

However, it is not recommended for use for lengths longer than 60m.

For applications where longer distances are required it is advised to purchase the Version 1 kit. Refer to the 3" & 4" Borehole Catalogue (p.7) for the cable length chart to ensure correct cable size is purchased.

TECHNICAL DATA

Dimensions and Weights

MODEL 1 ~220-240	DN	DIMENSIONS(mm)			WEIGHTS (kg)		
		P	M	T	P	M	T
3 SDM 2 / 8	1"	377	288	665	1.8	4.0	5.8
3 SDM 2 / 11	1"	444	308	752	2.1	4.8	6.9
3 SDM 2 / 15	1"	535	338	873	2.4	5.6	8.0
3 SDM 2 / 21	1"	694	368	1062	3.2	6.4	9.6
3 SDM 2 / 27	1"	830	408	1238	3.5	7.5	11.0
3 SDM 2 / 33	1"	966	448	1414	4.3	8.7	13.0
3 SDM 2 / 39	1"	1101	493	1594	4.9	10.0	14.9
3 SDM 2 / 47	1"	1306	543	1849	5.8	11.3	17.1

Installing a Borehole Pump and Motor

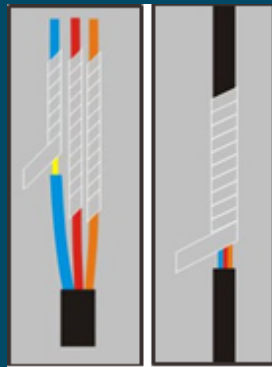
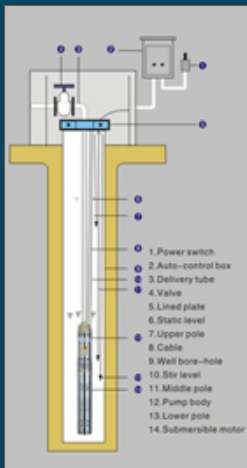

SINGLE PHASE 3" OIL FILLED BOREHOLE MOTOR CAPACITOR RATINGS		
kW	Capacitor (mF)	Running Amps
0.18	12	2.2
0.25	16	3.9
0.37	20	4.2
0.55	25	4.5
0.75	35	6
1.1	45	9
1.5	55	10.3

Maximum Cable Length From Pump To Starter

TYPE	kW	$i_n(A)$	1.5 mm ²	2.5 mm ²	4 mm ²	6 mm ²	10 mm ²
220V~/50H	0.18	2.2	171	290			
	0.25	3.9	122	207			
	0.37	4.2	111	185	295		
	0.55	4.5	80	133	211	315	
	0.75	6	58	96	153	229	377
	1.1	9	48	79	153	190	316
	1.5	10.3	34	57	92	137	228

Note: Unit c/w maximum 1.5mm 4 core cable.

However, it is not recommended for use for lengths longer than 60m.

For applications where longer distances are required it is advised to purchase the Version 1 kit. Refer to the 3" & 4" Borehole Catalogue (p.7) for the cable length chart to ensure correct cable size is purchased.

PUMP CONTROLLER

MA CONTROL BOX SINGLE PHASE

Technical data

This single phase control box is equipped with a capacitor and thermal over-load protector.

Application range

Type of motor: Single phase motor
Motor power: 0.18-1.5kW
Voltage: 220V ~240V
Frequency: 50Hz

Product functions

Provides basic protection against short circuiting and over current.

Operating Method

Manual control

Installation environment index

Grade protection: IP44
Environment temperature: -25oC to 55oC
Environment humidity: (20-90)%RH

POWER		RUNNING CAPACITOR	MCB
kW	HP	Microfarad (µF)	Amp
0.18	0.25	12	8
0.25	0.39	16	8
0.37	0.50	20	8
0.55	0.75	25	10
0.75	1.00	35	15
1.1	1.50	45	15
1.5	2.00	55	20

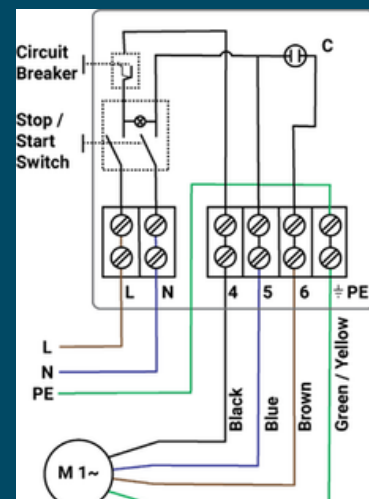



+27 62 375 5088

+27 65 321 5803

thewatersolarcompany.co.za