



REVERSE  
OSMOSIS  
SYSTEM BRO  
1500GPD  
*Catalogue*

## System Overview

- **Production: 0.25m<sup>3</sup>/hr (6m<sup>3</sup>/day)**
- **Membranes: 4040 x 1**
- **Feed TDS range: ≤ 2000ppm with standard membrane**
- **Typical salt rejection: 95 - 99%**
- **Power supply: 220V 50Hz Single phase**

## Material Of Construction

- **Frame Work: SS304**
- **Low pressure piping: UPVC Class 16**
- **High pressure piping: UPVC Class 16**
- **Pressure vessels: FRP 300psi**
- **Pumps: SS304**
- **Control Box: Mild steel epoxy coated**
- **Pre-filter housings: Big Blue 10"**

## Instrumentation

- **Pressure gauges: Pre & Post filter, Pre & Post membranes**
- **Pressure switches: Low pressure & high pressure**
- **Micro-processor for system automation**

## Feed Water Conditions

- **Temperature: 5 - 35 ° C**
- **TDS: ≤ 2000ppm with standard membrane**
- **SDI: < 5**
- **pH: 4 - 9**
- **Free Chlorine: Undetectable**
- **Iron: < 0.1ppm**
- **Manganese: < 0.05 ppm**

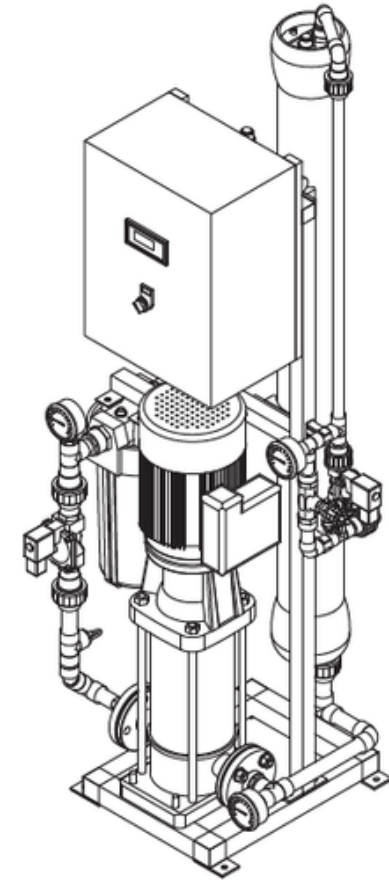
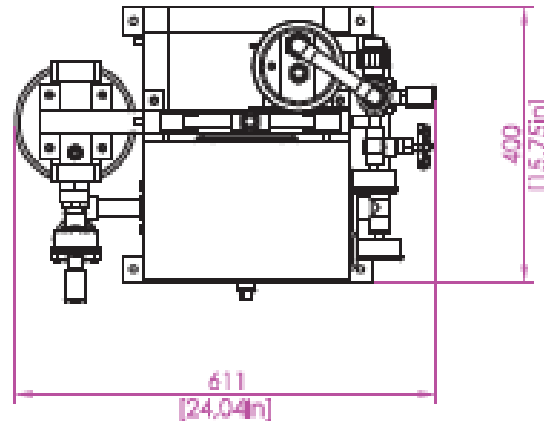
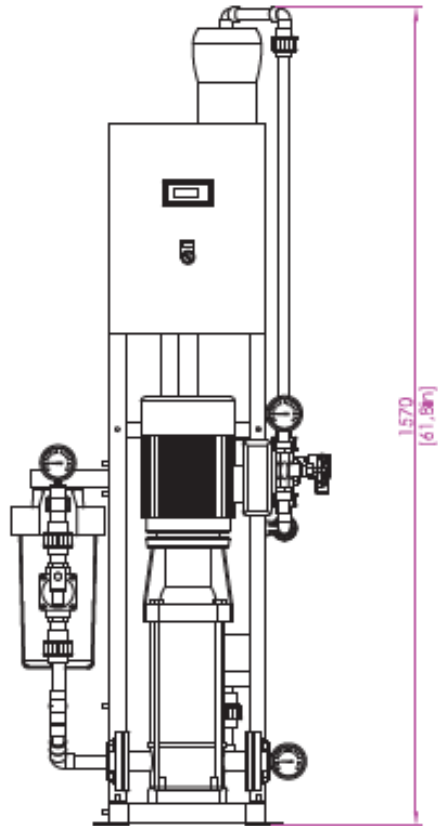

CRATED DIMENSION L(MM) * W (MM)* H(MM)	CRATED VOLUME (CUBIC METER)	GROSS WEIGHT (KG)	SYSTEM DIMENSION L(MM) * W (MM)* H(MM)	NET WEIGHT (KG)
740*560*1690	0.70	102	611*400*1570	76

**\*Specifications and dimensions subject to change**

**\*Permeate flows are maximums and may vary depending on feed water conditions**



+27 62 375 5088



+27 65 321 5803



<https://www.thewatersolarcompany.co.za/>



<https://maps.app.goo.gl/MBR2LMW3T6f9TtHV9>



<https://www.facebook.com/watersolarcompany>



<https://www.youtube.com/@TheWaterSolarCompany/>



<https://www.instagram.com/watersolarcompany2023/>